

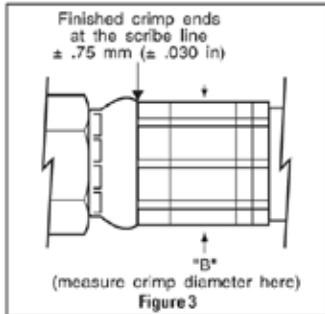

Boston

Boston Hose with Z-Series Crimp Style T-400, T-400-17, T-407-1, T-460, T-462, T-465



HOSE PART #	HOSE END PREFIX	COLLET PART #	SPACER RING COLOR	SPACER RING PART #	FLAT SIDE UP/DOWN	CATALOG FIGURE	CRIMP DIA. "B"	
							±.15 mm	±.006 in
H010506	06 'Z'	ET400DC-M195S	BK	T-400-10	DN	3	20.62 mm	.812 in
H010508	08 'Z'	ET400DC-M230S	BK/TN	T-400-46R	UP	3	24.38 mm	.960 in
H010604	04 'Z'	ET400DC-M150S	PR	ET1000SR-M100A	UP	3	15.60 mm	.614 in
H010606	06 'Z'	ET400DC-M195S	PR	ET1000SR-M100A	UP	3	20.07 mm	.790 in
H010608	08 'Z'	ET400DC-M230S	BK/TN	T-400-46R	UP	3	24.38 mm	.960 in
H11504	04 'Z'	ET400DC-M150S	BK/RD	T-400-47R	UP	3	16.94 mm	.667 in
H11506	06 'Z'	ET400DC-M195S	LG	ET1000SR-M190D	UP	3	21.62 mm	.851 in
H11508	08 'Z'	ET400DC-M230S	BK/TN	T-400-46R	UP	3	24.38 mm	.960 in
H11604	04 'Z'	ET400DC-M150S	YW	T-400-62	UP	3	16.74 mm	.659 in
H11606	06 'Z'	ET400DC-M195S	PR	ET1000SR-M100A	UP	3	20.07 mm	.790 in
H11608	08 'Z'	ET400DC-M230S	BK/TN	T-400-46R	UP	3	24.38 mm	.960 in
H177604	04 'Z'	ET400DC-M150S	YW	T-400-62	UP	3	16.74 mm	.659 in
H177606	06 'Z'	ET400DC-M195S	PR	ET1000SR-M100A	UP	3	20.07 mm	.790 in
H177608	08 'Z'	ET400DC-M230S	BK/TN	T-400-46R	UP	3	24.38 mm	.960 in
H177704	04 'Z'	ET400DC-M150S	PR	ET1000SR-M100A	UP	3	15.60 mm	.614 in
H177706	06 'Z'	ET400DC-M195S	PR	ET1000SR-M100A	UP	3	20.07 mm	.790 in
H177708	08 'Z'	ET400DC-M230S	BK/TN	T-400-46R	UP	3	24.38 mm	.960 in
H181204	04 'Z'	ET400DC-M150S	BK/RD	T-400-47R	UP	3	16.94 mm	.667 in
H181206	06 'Z'	ET400DC-M195S	GR	T-400-37	UP	3	19.66 mm	.774 in
H181208	08 'Z'	ET400DC-M230S	BK/TN	T-400-46R	UP	3	24.38 mm	.960 in
H198104	04 'Z'	ET400DC-M150S	YW	T-400-62	UP	3	16.74 mm	.659 in
H198106	06 'Z'	ET400DC-M195S	GR	T-400-37	UP	3	19.66 mm	.774 in
H198108	08 'Z'	ET400DC-M230S	PR	ET1000SR-M100A	UP	3	23.37 mm	.920 in
H198206	06 'Z'	ET400DC-M195S	BK	T-400-10	DN	3	20.62 mm	.812 in
H198208	08 'Z'	ET400DC-M230S	BK/TN	T-400-46R	UP	3	24.38 mm	.960 in
H26504	04 'Z'	ET400DC-M150S	PR	ET1000SR-M100A	UP	3	15.60 mm	.614 in
H26506	06 'Z'	ET400DC-M195S	GR	T-400-37	UP	3	19.66 mm	.774 in
H26508	08 'Z'	ET400DC-M230S	BK	T-400-10	DN	3	23.98 mm	.944 in
H27504	04 'Z'	ET400DC-M150S	PR	ET1000SR-M100A	UP	3	15.60 mm	.614 in

BK=Black BU=Blue OR=Orange RD=Red
 TN=Tan WH=White YW=Yellow SV=Silver
 MG=Magenta GY=Gray GR=Green
 BR=Brown PR=Purple LG=Light Green

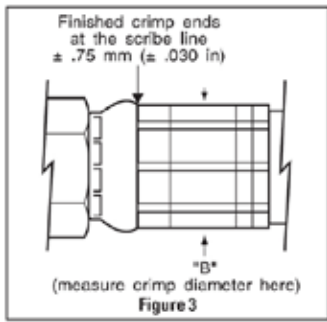

Boston Hose with Z-Series Crimp Style

T-400, T-400-17, T-407-1, T-460, T-462, T-465

HOSE PART #	HOSE END PREFIX	COLLET PART #	SPACER RING COLOR	SPACER RING PART #	FLAT SIDE UP/DOWN	CATALOG FIGURE	CRIMP DIA. "B"	
							±.15 mm	±.006 in
H27506	06 'Z'	ET400DC-M195S	GR	T-400-37	UP	3	19.66 mm	.774 in
H27508	08 'Z'	ET400DC-M230S	BK	T-400-10	DN	3	23.98 mm	.944 in
H334504	04 'Z'	ET400DC-M150S	TN	T-400-112	UP	3	15.88 mm	.625 in
H334506	06 'Z'	ET400DC-M195S	GR	T-400-37	UP	3	19.69 mm	.775 in
H334508	08 'Z'	ET400DC-M230S	BK	T-400-10	DN	3	23.88 mm	.940 in
H600208	08 'Z'	ET400DC-M230S	BK/TN	T-400-46R	UP	3	24.38 mm	.960 in
H994904	04 'Z'	ET400DC-M150S	YW	T-400-62	UP	3	16.74 mm	.659 in
H994906	06 'Z'	ET400DC-M195S	PR	ET1000SR-M100A	UP	3	20.07 mm	.790 in
H994908	08 'Z'	ET400DC-M230S	BK/TN	T-400-46R	UP	3	24.38 mm	.960 in

BK=Black BU=Blue OR=Orange RD=Red
 TN=Tan WH=White YW=Yellow SV=Silver
 MG=Magenta GY=Gray GR=Green
 BR=Brown PR=Purple LG=Light Green

Boston Hose with Z-Series Crimp Style

T-420

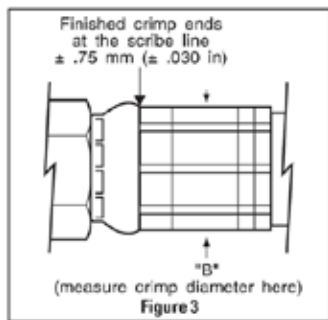

HOSE PART #	HOSE END PREFIX	COLLET PART #	SPACER RING COLOR	SPACER RING PART #	FLAT SIDE UP/DOWN	CATALOG FIGURE	CRIMP DIA. "B"
							±.15 mm ±.006 in
H010506	06 'Z'	ET400DC-M195S	BK	T-400-10	DN	3	20.62 mm .812 in
H010508	08 'Z'	ET400DC-M230S	BK/TN	T-400-46R	UP	3	24.38 mm .960 in
H010510	10 'Z'	T-420-85C	BR	ET420SR-M495A	UP	3	27.43 mm 1.080 in
H010512	12 'Z'	T-420-86C	BK/OR	T-420-81R	UP	3	32.92 mm 1.296 in
H010520	20 'Z'	ET420DC-M480S	N/A	N/A	N/A	3	49.78 mm 1.960 in
H010604	04 'Z'	ET400DC-M150S	PR	ET1000SR-M100A	UP	3	15.60 mm .614 in
H010606	06 'Z'	ET400DC-M195S	PR	ET1000SR-M100A	UP	3	20.07 mm .790 in
H010608	08 'Z'	ET400DC-M230S	BK/TN	T-400-46R	UP	3	24.38 mm .960 in
H010610	10 'Z'	T-420-85C	BR	ET420SR-M495A	UP	3	27.43 mm 1.080 in
H036316	16 'Z'	ET420DC-M380S	N/A	N/A	N/A	3	41.40 mm 1.630 in
H11504	04 'Z'	ET400DC-M150S	BK/RD	T-400-47R	UP	3	16.94 mm .667 in
H11506	06 'Z'	ET400DC-M195S	LG	ET1000SR-M190D	UP	3	21.62 mm .851 in
H11508	08 'Z'	ET400DC-M230S	BK/TN	T-400-46R	UP	3	24.38 mm .960 in
H11512	12 'Z'	T-420-86C	BK/OR	T-420-81R	UP	3	32.92 mm 1.296 in
H11516	16 'Z'	ET420DC-M380S	N/A	N/A	N/A	3	41.40 mm 1.630 in
H11520	20 'Z'	ET420DC-M480S	N/A	N/A	N/A	3	49.78 mm 1.960 in
H11604	04 'Z'	ET400DC-M150S	YW	T-400-62	UP	3	16.74 mm .659 in
H11606	06 'Z'	ET400DC-M195S	PR	ET1000SR-M100A	UP	3	20.07 mm .790 in
H11608	08 'Z'	ET400DC-M230S	BK/TN	T-400-46R	UP	3	24.38 mm .960 in
H157112	12 'Z'	T-420-86C	BK/OR	T-420-81R	UP	3	32.92 mm 1.296 in
H177604	04 'Z'	ET400DC-M150S	YW	T-400-62	UP	3	16.74 mm .659 in
H177606	06 'Z'	ET400DC-M195S	PR	ET1000SR-M100A	UP	3	20.07 mm .790 in
H177608	08 'Z'	ET400DC-M230S	BK/TN	T-400-46R	UP	3	24.38 mm .960 in
H177610	10 'Z'	T-420-85C	BK/OR	T-420-81R	UP	3	28.55 mm 1.124 in
H177612	12 'Z'	T-420-86C	BK/OR	T-420-81R	UP	3	32.92 mm 1.296 in
H177616	16 'Z'	ET420DC-M380S	N/A	N/A	N/A	3	41.40 mm 1.630 in
H177620	20 'Z'	ET420DC-M480S	N/A	N/A	N/A	3	49.78 mm 1.960 in
H177704	04 'Z'	ET400DC-M150S	PR	ET1000SR-M100A	UP	3	15.60 mm .614 in
H177706	06 'Z'	ET400DC-M195S	PR	ET1000SR-M100A	UP	3	20.07 mm .790 in

*T-420-25 adapter ring required when using ET400 Series Collets.

BK=Black BU=Blue OR=Orange RD=Red
 TN=Tan WH=White YW=Yellow SV=Silver
 MG=Magenta GY=Gray GR=Green
 BR=Brown PR=Purple LG=Light Green

Boston Hose with Z-Series Crimp Style

T-420

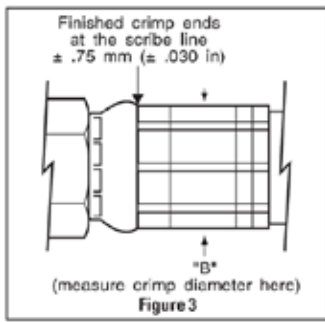

HOSE PART #	HOSE END PREFIX	COLLET PART #	SPACER RING COLOR	SPACER RING PART #	FLAT SIDE UP/DOWN	CATALOG FIGURE	CRIMP DIA. "B"	
							±.15 mm	±.006 in
H177708	08 'Z'	ET400DC-M230S	BK/TN	T-400-46R	UP	3	24.38 mm	.960 in
H181204	04 'Z'	ET400DC-M150S	BK/RD	T-400-47R	UP	3	16.94 mm	.667 in
H181206	06 'Z'	ET400DC-M195S	GR	T-400-37	UP	3	19.66 mm	.774 in
H181208	08 'Z'	ET400DC-M230S	BK/TN	T-400-46R	UP	3	24.38 mm	.960 in
H181210	10 'Z'	T-420-85C	BK/OR	T-420-81R	UP	3	28.55 mm	1.124 in
H181212	12 'Z'	T-420-86C	BK/OR	T-420-81R	UP	3	32.92 mm	1.296 in
H181216	16 'Z'	ET420DC-M380S	N/A	N/A	N/A	3	41.40 mm	1.630 in
H181220	20 'Z'	ET420DC-M480S	N/A	N/A	N/A	3	49.78 mm	1.960 in
H198104	04 'Z'	ET400DC-M150S	YW	T-400-62	UP	3	16.74 mm	.659 in
H198106	06 'Z'	ET400DC-M195S	GR	T-400-37	UP	3	19.66 mm	.774 in
H198108	08 'Z'	ET400DC-M230S	PR	ET1000SR-M100A	UP	3	23.37 mm	.920 in
H198206	06 'Z'	ET400DC-M195S	BK	T-400-10	DN	3	20.62 mm	.812 in
H198208	08 'Z'	ET400DC-M230S	BK/TN	T-400-46R	UP	3	24.38 mm	.960 in
H198210	10 'Z'	T-420-85C	BR	ET420SR-M495A	UP	3	27.43 mm	1.080 in
H198212	12 'Z'	T-420-86C	BR	ET420SR-M495A	UP	3	31.75 mm	1.250 in
H198216	16 'Z'	ET420DC-M380S	N/A	N/A	N/A	3	41.40 mm	1.630 in
H26504	04 'Z'	ET400DC-M150S	PR	ET1000SR-M100A	UP	3	15.60 mm	.614 in
H26506	06 'Z'	ET400DC-M195S	GR	T-400-37	UP	3	19.66 mm	.774 in
H26508	08 'Z'	ET400DC-M230S	BK	T-400-10	DN	3	23.98 mm	.944 in
H26512	12 'Z'	T-420-86C	PK	ET420SR-M660A	UP	3	31.04 mm	1.222 in
H26516	16 'Z'	ET420DC-M380S	OR	T-420-29	UP	3	40.26 mm	1.585 in
H27504	04 'Z'	ET400DC-M150S	PR	ET1000SR-M100A	UP	3	15.60 mm	.614 in
H27506	06 'Z'	ET400DC-M195S	GR	T-400-37	UP	3	19.66 mm	.774 in
H27508	08 'Z'	ET400DC-M230S	BK	T-400-10	DN	3	23.98 mm	.944 in
H27512	12 'Z'	T-420-86C	PK	ET420SR-M660A	UP	3	31.04 mm	1.222 in
H27516	16 'Z'	ET420DC-M380S	N/A	N/A	N/A	3	41.40 mm	1.630 in
H334504	04 'Z'	ET400DC-M150S	TN	T-400-112	UP	3	15.88 mm	.625 in
H334506	06 'Z'	ET400DC-M195S	GR	T-400-37	UP	3	19.69 mm	.775 in
H334508	08 'Z'	ET400DC-M230S	BK	T-400-10	DN	3	23.88 mm	.940 in

*T-420-25 adapter ring required when using ET400 Series Collets.

BK=Black BU=Blue OR=Orange RD=Red
 TN=Tan WH=White YW=Yellow SV=Silver
 MG=Magenta GY=Gray GR=Green
 BR=Brown PR=Purple LG=Light Green

Boston Hose with Z-Series Crimp Style

T-420

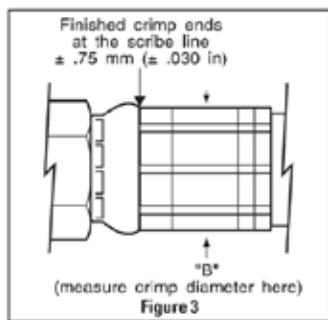

HOSE PART #	HOSE END PREFIX	COLLET PART #	SPACER RING COLOR	SPACER RING PART #	FLAT SIDE UP/DOWN	CATALOG FIGURE	CRIMP DIA. "B"
							±.15 mm ±.006 in
H600208	08 'Z'	ET400DC-M230S	BK/TN	T-400-46R	UP	3	24.38 mm .960 in
H600212	12 'Z'	T-420-86C	BK/OR	T-420-81R	UP	3	32.92 mm 1.296 in
H600216	16 'Z'	ET420DC-M380S	N/A	N/A	N/A	3	41.40 mm 1.630 in
H600816	16 'Z'	ET420DC-M380S	N/A	N/A	N/A	3	41.40 mm 1.630 in
H600820	20 'Z'	ET420DC-M480S	N/A	N/A	N/A	3	49.78 mm 1.960 in
H600920	20 'Z'	ET420DC-M480S	N/A	N/A	N/A	3	49.78 mm 1.960 in
H962212	12 'Z'	T-420-86C	BR	ET420SR-M495A	UP	3	31.75 mm 1.250 in
H962216	16 'Z'	ET420DC-M380S	N/A	N/A	N/A	3	41.40 mm 1.630 in
H994904	04 'Z'	ET400DC-M150S	YW	T-400-62	UP	3	16.74 mm .659 in
H994906	06 'Z'	ET400DC-M195S	PR	ET1000SR-M100A	UP	3	20.07 mm .790 in
H994908	08 'Z'	ET400DC-M230S	BK/TN	T-400-46R	UP	3	24.38 mm .960 in
H994912	12 'Z'	T-420-86C	BK/OR	T-420-81R	UP	3	32.92 mm 1.296 in
H994916	16 'Z'	ET420DC-M380S	N/A	N/A	N/A	3	41.40 mm 1.630 in

*T-420-25 adapter ring required when using ET400 Series Collets.

BK=Black BU=Blue OR=Orange RD=Red
 TN=Tan WH=White YW=Yellow SV=Silver
 MG=Magenta GY=Gray GR=Green
 BR=Brown PR=Purple LG=Light Green

Boston Hose with Z-Series Crimp Style

T-480

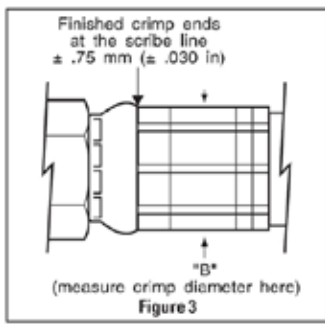

HOSE PART #	HOSE END PREFIX	COLLET PART #	SPACER RING COLOR	SPACER RING PART #	FLAT SIDE UP/DOWN	CATALOG FIGURE	CRIMP DIA. "B"	
							±.15 mm	±.006 in
H010506	06 'Z'	ET400DC-M195S	BK	T-400-10	DN	3	20.62 mm	.812 in
H010508	08 'Z'	ET400DC-M230S	BK/TN	T-400-46R	UP	3	24.38 mm	.960 in
H010510	10 'Z'	T-420-85C	BR	ET420SR-M495A	UP	3	27.43 mm	1.080 in
H010512	12 'Z'	T-420-86C	BK/OR	T-420-81R	UP	3	32.92 mm	1.296 in
H010520	20 'Z'	ET420DC-M480S	BU	T-480-68	N/A	3	49.78 mm	1.960 in
H010604	04 'Z'	ET400DC-M150S	PR	ET1000SR-M100A	UP	3	15.60 mm	.614 in
H010606	06 'Z'	ET400DC-M195S	PR	ET1000SR-M100A	UP	3	20.07 mm	.790 in
H010608	08 'Z'	ET400DC-M230S	BK/TN	T-400-46R	UP	3	24.38 mm	.960 in
H010610	10 'Z'	T-420-85C	BR	ET420SR-M495A	UP	3	27.43 mm	1.080 in
H036316	16 'Z'	ET420DC-M380S	BU	T-480-68	N/A	3	41.40 mm	1.630 in
H11504	04 'Z'	ET400DC-M150S	BK/RD	T-400-47R	UP	3	16.94 mm	.667 in
H11506	06 'Z'	ET400DC-M195S	LG	ET1000SR-M190D	UP	3	21.62 mm	.851 in
H11508	08 'Z'	ET400DC-M230S	BK/TN	T-400-46R	UP	3	24.38 mm	.960 in
H11512	12 'Z'	T-420-86C	BK/OR	T-420-81R	UP	3	32.92 mm	1.296 in
H11516	16 'Z'	ET420DC-M380S	BU	T-480-68	N/A	3	41.40 mm	1.630 in
H11520	20 'Z'	ET420DC-M480S	BU	T-480-68	N/A	3	49.78 mm	1.960 in
H11604	04 'Z'	ET400DC-M150S	YW	T-400-62	UP	3	16.74 mm	.659 in
H11606	06 'Z'	ET400DC-M195S	PR	ET1000SR-M100A	UP	3	20.07 mm	.790 in
H11608	08 'Z'	ET400DC-M230S	BK/TN	T-400-46R	UP	3	24.38 mm	.960 in
H157112	12 'Z'	T-420-86C	BK/OR	T-420-81R	UP	3	32.92 mm	1.296 in
H177604	04 'Z'	ET400DC-M150S	YW	T-400-62	UP	3	16.74 mm	.659 in
H177606	06 'Z'	ET400DC-M195S	PR	ET1000SR-M100A	UP	3	20.07 mm	.790 in
H177608	08 'Z'	ET400DC-M230S	BK/TN	T-400-46R	UP	3	24.38 mm	.960 in
H177610	10 'Z'	T-420-85C	BK/OR	T-420-81R	UP	3	28.55 mm	1.124 in
H177612	12 'Z'	T-420-86C	BK/OR	T-420-81R	UP	3	32.92 mm	1.296 in
H177616	16 'Z'	ET420DC-M380S	BU	T-480-68	N/A	3	41.40 mm	1.630 in
H177620	20 'Z'	ET420DC-M480S	BU	T-480-68	N/A	3	49.78 mm	1.960 in
H177704	04 'Z'	ET400DC-M150S	PR	ET1000SR-M100A	UP	3	15.60 mm	.614 in
H177706	06 'Z'	ET400DC-M195S	PR	ET1000SR-M100A	UP	3	20.07 mm	.790 in

*T-420-25 adapter ring required when using ET400 Series Collets.

BK=Black BU=Blue OR=Orange RD=Red
 TN=Tan WH=White YW=Yellow SV=Silver
 MG=Magenta GY=Gray GR=Green
 BR=Brown PR=Purple LG=Light Green

Boston Hose with Z-Series Crimp Style

T-480

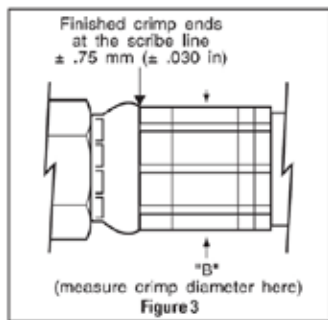

HOSE PART #	HOSE END PREFIX	COLLET PART #	SPACER RING COLOR	SPACER RING PART #	FLAT SIDE UP/DOWN	CATALOG FIGURE	CRIMP DIA. "B"
							±.15 mm ±.006 in
H177708	08 'Z'	ET400DC-M230S	BK/TN	T-400-46R	UP	3	24.38 mm .960 in
H181204	04 'Z'	ET400DC-M150S	BK/RD	T-400-47R	UP	3	16.94 mm .667 in
H181206	06 'Z'	ET400DC-M195S	GR	T-400-37	UP	3	19.66 mm .774 in
H181208	08 'Z'	ET400DC-M230S	BK/TN	T-400-46R	UP	3	24.38 mm .960 in
H181210	10 'Z'	T-420-85C	BK/OR	T-420-81R	UP	3	28.55 mm 1.124 in
H181212	12 'Z'	T-420-86C	BK/OR	T-420-81R	UP	3	32.92 mm 1.296 in
H181216	16 'Z'	ET420DC-M380S	BU	T-480-68	N/A	3	41.40 mm 1.630 in
H181220	20 'Z'	ET420DC-M480S	BU	T-480-68	N/A	3	49.78 mm 1.960 in
H198104	04 'Z'	ET400DC-M150S	YW	T-400-62	UP	3	16.74 mm .659 in
H198106	06 'Z'	ET400DC-M195S	GR	T-400-37	UP	3	19.66 mm .774 in
H198108	08 'Z'	ET400DC-M230S	PR	ET1000SR-M100A	UP	3	23.37 mm .920 in
H198206	06 'Z'	ET400DC-M195S	BK	T-400-10	DN	3	20.62 mm .812 in
H198208	08 'Z'	ET400DC-M230S	BK/TN	T-400-46R	UP	3	24.38 mm .960 in
H198210	10 'Z'	T-420-85C	BR	ET420SR-M495A	UP	3	27.43 mm 1.080 in
H198212	12 'Z'	T-420-86C	BR	ET420SR-M495A	UP	3	31.75 mm 1.250 in
H198216	16 'Z'	ET420DC-M380S	BU	T-480-68	N/A	3	41.40 mm 1.630 in
H26504	04 'Z'	ET400DC-M150S	PR	ET1000SR-M100A	UP	3	15.60 mm .614 in
H26506	06 'Z'	ET400DC-M195S	GR	T-400-37	UP	3	19.66 mm .774 in
H26508	08 'Z'	ET400DC-M230S	BK	T-400-10	DN	3	23.98 mm .944 in
H26512	12 'Z'	T-420-86C	PK	ET420SR-M660A	UP	3	31.04 mm 1.222 in
H26516	16 'Z'	ET420DC-M380S	OR	T-420-29	UP	3	40.26 mm 1.585 in
H27504	04 'Z'	ET400DC-M150S	PR	ET1000SR-M100A	UP	3	15.60 mm .614 in
H27506	06 'Z'	ET400DC-M195S	GR	T-400-37	UP	3	19.66 mm .774 in
H27508	08 'Z'	ET400DC-M230S	BK	T-400-10	DN	3	23.98 mm .944 in
H27512	12 'Z'	T-420-86C	PK	ET420SR-M660A	UP	3	31.04 mm 1.222 in
H27516	16 'Z'	ET420DC-M380S	BU	T-480-68	N/A	3	41.40 mm 1.630 in
H334504	04 'Z'	ET400DC-M150S	TN	T-400-112	UP	3	15.88 mm .625 in
H334506	06 'Z'	ET400DC-M195S	GR	T-400-37	UP	3	19.69 mm .775 in
H334508	08 'Z'	ET400DC-M230S	BK	T-400-10	DN	3	23.88 mm .940 in

*T-420-25 adapter ring required when using ET400 Series Collets.

BK=Black BU=Blue OR=Orange RD=Red
 TN=Tan WH=White YW=Yellow SV=Silver
 MG=Magenta GY=Gray GR=Green
 BR=Brown PR=Purple LG=Light Green

Boston Hose with Z-Series Crimp Style

T-480

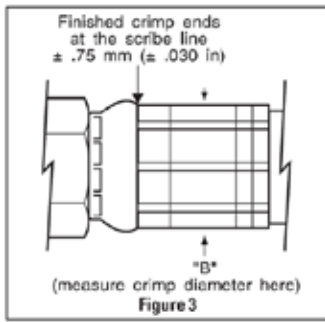

HOSE PART #	HOSE END PREFIX	COLLET PART #	SPACER RING COLOR	SPACER RING PART #	FLAT SIDE UP/DOWN	CATALOG FIGURE	CRIMP DIA. "B"	
							±.15 mm	±.006 in
H600208	08 'Z'	ET400DC-M230S	BK/TN	T-400-46R	UP	3	24.38 mm	.960 in
H600212	12 'Z'	T-420-86C	BK/OR	T-420-81R	UP	3	32.92 mm	1.296 in
H600216	16 'Z'	ET420DC-M380S	BU	T-480-68	N/A	3	41.40 mm	1.630 in
H600816	16 'Z'	ET420DC-M380S	BU	T-480-68	N/A	3	41.40 mm	1.630 in
H600820	20 'Z'	ET420DC-M480S	BU	T-480-68	N/A	3	49.78 mm	1.960 in
H600920	20 'Z'	ET420DC-M480S	BU	T-480-68	N/A	3	49.78 mm	1.960 in
H962212	12 'Z'	T-420-86C	BR	ET420SR-M495A	UP	3	31.75 mm	1.250 in
H962216	16 'Z'	ET420DC-M380S	BU	T-480-68	N/A	3	41.40 mm	1.630 in
H962220	20 'Z'	ET420DC-M480S	BK/BU	T-420-82R	UP	3	48.26 mm	1.900 in
H994904	04 'Z'	ET400DC-M150S	YW	T-400-62	UP	3	16.74 mm	.659 in
H994906	06 'Z'	ET400DC-M195S	PR	ET1000SR-M100A	UP	3	20.07 mm	.790 in
H994908	08 'Z'	ET400DC-M230S	BK/TN	T-400-46R	UP	3	24.38 mm	.960 in
H994912	12 'Z'	T-420-86C	BK/OR	T-420-81R	UP	3	32.92 mm	1.296 in
H994916	16 'Z'	ET420DC-M380S	BU	T-480-68	N/A	3	41.40 mm	1.630 in

*T-420-25 adapter ring required when using ET400 Series Collets.

BK=Black BU=Blue OR=Orange RD=Red
 TN=Tan WH=White YW=Yellow SV=Silver
 MG=Magenta GY=Gray GR=Green
 BR=Brown PR=Purple LG=Light Green

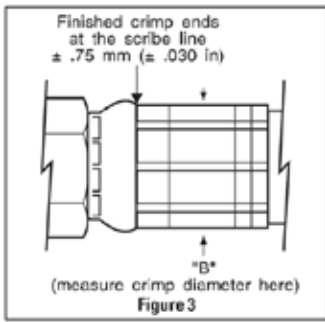

Boston Hose with Z-Series Crimp Style

ET1000

HOSE PART #	HOSE END PREFIX	COLLET PART #	SPACER RING COLOR	SPACER RING PART #	FLAT SIDE UP/DOWN	CATALOG FIGURE		CRIMP DIA. "B"
							±.15 mm	±.006 in
H010506	06 'Z'	ET400DC-M195S	BK	T-400-10	DN	3	20.62 mm	.812 in
H010508	08 'Z'	ET400DC-M230S	BK/TN	T-400-46R	UP	3	24.38 mm	.960 in
H010510	10 'Z'	T-420-85C	BR	ET420SR-M495A	UP	3	27.43 mm	1.080 in
H010512	12 'Z'	T-420-86C	BK/OR*	T-420-81R	UP	3	32.92 mm	1.296 in
H010520	20 'Z'	ET420DC-M480S	BK	T-400-10	DN	3	49.78 mm	1.960 in
H010604	04 'Z'	ET400DC-M150S	PR	ET1000SR-M100A	UP	3	15.60 mm	.614 in
H010606	06 'Z'	ET400DC-M195S	PR	ET1000SR-M100A	UP	3	20.07 mm	.790 in
H010608	08 'Z'	ET400DC-M230S	BK/TN	T-400-46R	UP	3	24.38 mm	.960 in
H010610	10 'Z'	T-420-85C	BR	ET420SR-M495A	UP	3	27.43 mm	1.080 in
H036316	16 'Z'	ET420DC-M380S	BK	T-400-10	DN	3	41.40 mm	1.630 in
H11504	04 'Z'	ET400DC-M150S	BK/RD	T-400-47R	UP	3	16.94 mm	.667 in
H11506	06 'Z'	ET400DC-M195S	LG	ET1000SR-M190D	UP	3	21.62 mm	.851 in
H11508	08 'Z'	ET400DC-M230S	BK/TN	T-400-46R	UP	3	24.38 mm	.960 in
H11512	12 'Z'	T-420-86C	BK/OR*	T-420-81R	UP	3	32.92 mm	1.296 in
H11516	16 'Z'	ET420DC-M380S	BK	T-400-10	DN	3	41.40 mm	1.630 in
H11520	20 'Z'	ET420DC-M480S	BK	T-400-10	DN	3	49.78 mm	1.960 in
H11604	04 'Z'	ET400DC-M150S	YW	T-400-62	UP	3	16.74 mm	.659 in
H11606	06 'Z'	ET400DC-M195S	PR	ET1000SR-M100A	UP	3	20.07 mm	.790 in
H11608	08 'Z'	ET400DC-M230S	BK/TN	T-400-46R	UP	3	24.38 mm	.960 in
H157112	12 'Z'	T-420-86C	BK/OR*	T-420-81R	UP	3	32.92 mm	1.296 in
H177604	04 'Z'	ET400DC-M150S	YW	T-400-62	UP	3	16.74 mm	.659 in
H177606	06 'Z'	ET400DC-M195S	PR	ET1000SR-M100A	UP	3	20.07 mm	.790 in
H177608	08 'Z'	ET400DC-M230S	BK/TN	T-400-46R	UP	3	24.38 mm	.960 in
H177610	10 'Z'	T-420-85C	BK/OR*	T-420-81R	UP	3	28.55 mm	1.124 in
H177612	12 'Z'	T-420-86C	BK/OR*	T-420-81R	UP	3	32.92 mm	1.296 in
H177616	16 'Z'	ET420DC-M380S	BK	T-400-10	DN	3	41.40 mm	1.630 in
H177620	20 'Z'	ET420DC-M480S	BK	T-400-10	DN	3	49.78 mm	1.960 in
H177704	04 'Z'	ET400DC-M150S	PR	ET1000SR-M100A	UP	3	15.60 mm	.614 in
H177706	06 'Z'	ET400DC-M195S	PR	ET1000SR-M100A	UP	3	20.07 mm	.790 in

*Requires a pusher extension, part number ET1000C-0012, to be placed on top of the spacer ring, when crimping with ET1000.

ET1000AR-001 adapter ring required when using ET400 Series Collets.

BK=Black BU=Blue OR=Orange RD=Red
 TN=Tan WH=White YW=Yellow SV=Silver
 MG=Magenta GY=Gray GR=Green
 BR=Brown PR=Purple LG=Light Green

Boston Hose with Z-Series Crimp Style

ET1000

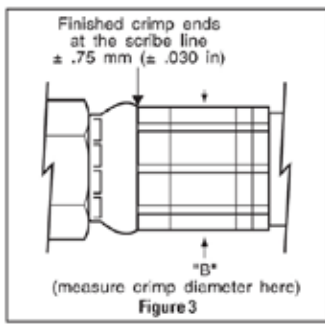

HOSE PART #	HOSE END PREFIX	COLLET PART #	SPACER RING COLOR	SPACER RING PART #	FLAT SIDE UP/DOWN	CATALOG FIGURE	CRIMP DIA. "B"	
							±.15 mm	±.006 in
H177708	08 'Z'	ET400DC-M230S	BK/TN	T-400-46R	UP	3	24.38 mm	.960 in
H181204	04 'Z'	ET400DC-M150S	BK/RD	T-400-47R	UP	3	16.94 mm	.667 in
H181206	06 'Z'	ET400DC-M195S	GR	T-400-37	UP	3	19.66 mm	.774 in
H181208	08 'Z'	ET400DC-M230S	BK/TN	T-400-46R	UP	3	24.38 mm	.960 in
H181210	10 'Z'	T-420-85C	BK/OR*	T-420-81R	UP	3	28.55 mm	1.124 in
H181212	12 'Z'	T-420-86C	BK/OR*	T-420-81R	UP	3	32.92 mm	1.296 in
H181216	16 'Z'	ET420DC-M380S	BK	T-400-10	DN	3	41.40 mm	1.630 in
H181220	20 'Z'	ET420DC-M480S	BK	T-400-10	DN	3	49.78 mm	1.960 in
H198104	04 'Z'	ET400DC-M150S	YW	T-400-62	UP	3	16.74 mm	.659 in
H198106	06 'Z'	ET400DC-M195S	GR	T-400-37	UP	3	19.66 mm	.774 in
H198108	08 'Z'	ET400DC-M230S	PR	ET1000SR-M100A	UP	3	23.37 mm	.920 in
H198206	06 'Z'	ET400DC-M195S	BK	T-400-10	DN	3	20.62 mm	.812 in
H198208	08 'Z'	ET400DC-M230S	BK/TN	T-400-46R	UP	3	24.38 mm	.960 in
H198210	10 'Z'	T-420-85C	BR	ET420SR-M495A	UP	3	27.43 mm	1.080 in
H198212	12 'Z'	T-420-86C	BR	ET420SR-M495A	UP	3	31.75 mm	1.250 in
H198216	16 'Z'	ET420DC-M380S	BK	T-400-10	DN	3	41.40 mm	1.630 in
H26504	04 'Z'	ET400DC-M150S	PR	ET1000SR-M100A	UP	3	15.60 mm	.614 in
H26506	06 'Z'	ET400DC-M195S	GR	T-400-37	UP	3	19.66 mm	.774 in
H26508	08 'Z'	ET400DC-M230S	BK	T-400-10	DN	3	23.98 mm	.944 in
H26512	12 'Z'	T-420-86C	PK*	ET420SR-M660A	UP	3	31.04 mm	1.222 in
H26516	16 'Z'	ET420DC-M380S	OR	T-420-29	UP	3	40.26 mm	1.585 in
H27504	04 'Z'	ET400DC-M150S	PR	ET1000SR-M100A	UP	3	15.60 mm	.614 in
H27506	06 'Z'	ET400DC-M195S	GR	T-400-37	UP	3	19.66 mm	.774 in
H27508	08 'Z'	ET400DC-M230S	BK	T-400-10	DN	3	23.98 mm	.944 in
H27512	12 'Z'	T-420-86C	PK*	ET420SR-M660A	UP	3	31.04 mm	1.222 in
H27516	6 'Z'	ET420DC-M380S	BK	T-400-10	DN	3	41.40 mm	1.630 in
H334504	04 'Z'	ET400DC-M150S	TN	T-400-112	UP	3	15.88 mm	.625 in
H334506	06 'Z'	ET400DC-M195S	GR	T-400-37	UP	3	19.69 mm	.775 in
H334508	08 'Z'	ET400DC-M230S	BK	T-400-10	DN	3	23.88 mm	.940 in

*Requires a pusher extension, part number ET1000C-0012, to be placed on top of the spacer ring, when crimping with ET1000.
 ET1000AR-001 adapter ring required when using ET400 Series Collets.

BK=Black BU=Blue OR=Orange RD=Red
 TN=Tan WH=White YW=Yellow SV=Silver
 MG=Magenta GY=Gray GR=Green
 BR=Brown PR=Purple LG=Light Green

Boston Hose with Z-Series Crimp Style

ET1000

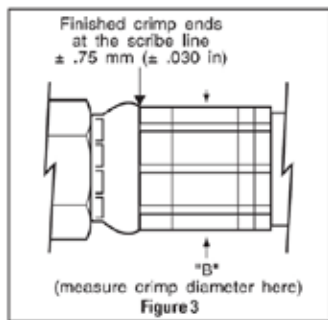

HOSE PART #	HOSE END PREFIX	COLLET PART #	SPACER RING COLOR	SPACER RING PART #	FLAT SIDE UP/DOWN	CATALOG FIGURE	CRIMP DIA. "B"
							±.15 mm ±.006 in
H600208	08 'Z'	ET400DC-M230S	BK/TN	T-400-46R	UP	3	24.38 mm .960 in
H600212	12 'Z'	T-420-86C	BK/OR*	T-420-81R	UP	3	32.92 mm 1.296 in
H600216	16 'Z'	ET420DC-M380S	BK	T-400-10	DN	3	41.40 mm 1.630 in
H600816	16 'Z'	ET420DC-M380S	BK	T-400-10	DN	3	41.40 mm 1.630 in
H600820	20 'Z'	ET420DC-M480S	BK	T-400-10	DN	3	49.78 mm 1.960 in
H600920	20 'Z'	ET420DC-M480S	BK	T-400-10	DN	3	49.78 mm 1.960 in
H962212	12 'Z'	T-420-86C	BR	ET420SR-M495A	UP	3	31.75 mm 1.250 in
H962216	16 'Z'	ET420DC-M380S	BK	T-400-10	DN	3	1.40 mm 1.630 in
H962220	20 'Z'	ET420DC-M480S	BK/BU	T-420-82R	UP	3	48.26 mm 1.900 in
H994904	04 'Z'	ET400DC-M150S	YW	T-400-62	UP	3	16.74 mm .659 in
H994906	06 'Z'	ET400DC-M195S	PR	ET1000SR-M100A	UP	3	20.07 mm .790 in
H994908	08 'Z'	ET400DC-M230S	BK/TN	T-400-46R	UP	3	24.38 mm .960 in
H994912	12 'Z'	T-420-86C	BK/OR*	T-420-81R	UP	3	32.92 mm 1.296 in
H994916	16 'Z'	ET420DC-M380S	BK	T-400-10	DN	3	41.40 mm 1.630 in

*Requires a pusher extension, part number ET1000C-0012, to be placed on top of the spacer ring, when crimping with ET1000.
ET1000AR-001 adapter ring required when using ET400 Series Collets.

BK=Black BU=Blue OR=Orange RD=Red
TN=Tan WH=White YW=Yellow SV=Silver
MG=Magenta GY=Gray GR=Green
BR=Brown PR=Purple LG=Light Green

Boston Hose with Z-Series Crimp Style ET4000, T-440

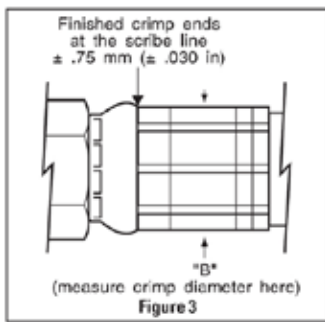

HOSE PART #	HOSE END PREFIX	COLLET PART #	SPACER RING COLOR	SPACER RING PART #	FLAT SIDE UP/DOWN	CATALOG FIGURE	CRIMP DIA. "B"	
							±.15 mm	±.006 in
H010506	06 'Z'	ET4000DC-M195S	BK	T-410-10	DN	3	20.62 mm	.812 in
H010508	08 'Z'	ET4000DC-M230S	BK/TN	T-440-78R	UP	3	24.38 mm	.960 in
H010510	10 'Z'	T-440-85C	BR	ET4000SR-M405A	UP	3	27.43 mm	1.080 in
H010512	12 'Z'	T-440-86C	BK/OR	T-440-81R	UP	3	32.92 mm	1.296 in
H010520	20 'Z'	ET4000DC-M480S	N/A	N/A	N/A	3	49.78 mm	1.960 in
H010604	04 'Z'	ET4000DC-M150S	PR	ET4000SR-M100A	UP	3	15.60 mm	.614 in
H010606	06 'Z'	ET4000DC-M195S	PR	ET4000SR-M100A	UP	3	20.07 mm	.790 in
H010608	08 'Z'	ET4000DC-M230S	BK/TN	T-440-78R	UP	3	24.38 mm	.960 in
H010610	10 'Z'	T-440-85C	BR	ET4000SR-M405A	UP	3	27.43 mm	1.080 in
H036316	16 'Z'	ET4000DC-M380S	N/A	N/A	N/A	3	41.40 mm	1.630 in
H11504	04 'Z'	ET4000DC-M150S	BK/RD	T-440-79R	UP	3	16.94 mm	.667 in
H11506	06 'Z'	ET4000DC-M195S	LG	ET4000SR-M190D	UP	3	21.62 mm	.851 in
H11508	08 'Z'	ET4000DC-M230S	BK/TN	T-440-78R	UP	3	24.38 mm	.960 in
H11512	12 'Z'	T-440-86C	BK/OR	T-440-81R	UP	3	32.92 mm	1.296 in
H11516	16 'Z'	ET4000DC-M380S	N/A	N/A	N/A	3	41.40 mm	1.630 in
H11520	20 'Z'	ET4000DC-M480S	N/A	N/A	N/A	3	49.78 mm	1.960 in
H11604	04 'Z'	ET4000DC-M150S	YW	T-410-41	UP	3	16.74 mm	.659 in
H11606	06 'Z'	ET4000DC-M195S	PR	ET4000SR-M100A	UP	3	20.07 mm	.790 in
H11608	08 'Z'	ET4000DC-M230S	BK/TN	T-440-78R	UP	3	24.38 mm	.960 in
H157112	12 'Z'	T-440-86C	BK/OR	T-440-81R	UP	3	32.92 mm	1.296 in
H177604	04 'Z'	ET4000DC-M150S	YW	T-410-41	UP	3	16.74 mm	.659 in
H177606	06 'Z'	ET4000DC-M195S	PR	ET4000SR-M100A	UP	3	20.07 mm	.790 in
H177608	08 'Z'	ET4000DC-M230S	BK/TN	T-440-78R	UP	3	24.38 mm	.960 in
H177610	10 'Z'	T-440-85C	BK/OR	T-440-81R	UP	3	28.55 mm	1.124 in
H177612	12 'Z'	T-440-86C	BK/OR	T-440-81R	UP	3	32.92 mm	1.296 in
H177616	16 'Z'	ET4000DC-M380S	N/A	N/A	N/A	3	41.40 mm	1.630 in
H177620	20 'Z'	ET4000DC-M480S	N/A	N/A	N/A	3	49.78 mm	1.960 in
H177704	04 'Z'	ET4000DC-M150S	PR	T4000SR-M100A	UP	3	15.60 mm	.614 in
H177706	06 'Z'	ET4000DC-M195S	PR	ET4000SR-M100A	UP	3	20.07 mm	.790 in

*T-410-25 adapter ring required when using ET400 Series Collets.

BK=Black BU=Blue OR=Orange RD=Red
 TN=Tan WH=White YW=Yellow SV=Silver
 MG=Magenta GY=Gray GR=Green
 BR=Brown PR=Purple LG=Light Green

Boston Hose with Z-Series Crimp Style

ET4000, T-440

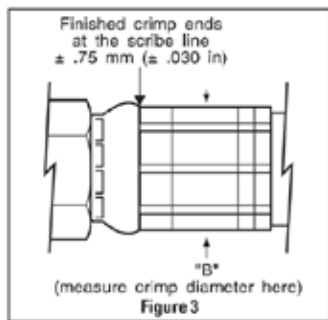

HOSE PART #	HOSE END PREFIX	COLLET PART #	SPACER RING COLOR	SPACER RING PART #	FLAT SIDE UP/DOWN	CATALOG FIGURE	CRIMP DIA. "B"
							±.15 mm ±.006 in
H177708	08 'Z'	ET400DC-M230S	BK/TN	T-440-78R	UP	3	24.38 mm .960 in
H181204	04 'Z'	ET400DC-M150S	BK/RD	T-440-79R	UP	3	16.94 mm .667 in
H181206	06 'Z'	ET400DC-M195S	GR	T-410-39	UP	3	19.66 mm .774 in
H181208	08 'Z'	ET400DC-M230S	BK/TN	T-440-78R	UP	3	24.38 mm .960 in
H181210	10 'Z'	T-440-85C	BK/OR	T-440-81R	UP	3	28.55 mm 1.124 in
H181212	12 'Z'	T-440-86C	BK/OR	T-440-81R	UP	3	32.92 mm 1.296 in
H181216	16 'Z'	ET400DC-M380S	N/A	N/A	N/A	3	41.40 mm 1.630 in
H181220	20 'Z'	ET400DC-M480S	N/A	N/A	N/A	3	49.78 mm 1.960 in
H198104	04 'Z'	ET400DC-M150S	YW	T-410-41	UP	3	16.74 mm .659 in
H198106	06 'Z'	ET400DC-M195S	GR	T-410-39	UP	3	19.66 mm .774 in
H198108	08 'Z'	ET400DC-M230S	PR	ET4000SR-M100A	UP	3	23.37 mm .920 in
H198206	06 'Z'	ET400DC-M195S	BK	T-410-10	DN	3	20.62 mm .812 in
H198208	08 'Z'	ET400DC-M230S	BK/TN	T-440-78R	UP	3	24.38 mm .960 in
H198210	10 'Z'	T-440-85C	BR	ET4000SR-M405A	UP	3	27.43 mm 1.080 in
H198212	12 'Z'	T-440-86C	BR	ET4000SR-M405A	UP	3	31.75 mm 1.250 in
H198216	16 'Z'	ET400DC-M380S	N/A	N/A	N/A	3	41.40 mm 1.630 in
H26504	04 'Z'	ET400DC-M150S	PR	ET4000SR-M100A	UP	3	15.60 mm .614 in
H26506	06 'Z'	ET400DC-M195S	GR	T-400-37	UP	3	19.66 mm .774 in
H26508	08 'Z'	ET400DC-M230S	BK	T-410-10	DN	3	23.98 mm .944 in
H26512	12 'Z'	T-440-86C	PK	ET4000SR-M560A	UP	3	31.04 mm 1.222 in
H26516	16 'Z'	ET400DC-M380S	OR	T-410-93	UP	3	40.26 mm 1.585 in
H27504	04 'Z'	ET400DC-M150S	PR	ET4000SR-M100A	UP	3	15.60 mm .614 in
H27506	06 'Z'	ET400DC-M195S	GR	T-400-37	UP	3	19.66 mm .774 in
H27508	08 'Z'	ET400DC-M230S	BK	T-410-10	DN	3	23.98 mm .944 in
H27512	12 'Z'	T-440-86C	PK	ET4000SR-M560A	UP	3	31.04 mm 1.222 in
H27516	16 'Z'	ET400DC-M380S	N/A	N/A	N/A	3	41.40 mm 1.630 in
H334504	04 'Z'	ET400DC-M150S	TN	T-410-42	UP	3	15.88 mm .625 in
H334506	06 'Z'	ET400DC-M195S	GR	T-410-39	UP	3	19.69 mm .775 in
H334508	08 'Z'	ET400DC-M230S	BK	T-410-10	DN	3	23.88 mm .940 in

*T-410-25 adapter ring required when using ET400 Series Collets.

BK=Black BU=Blue OR=Orange RD=Red
 TN=Tan WH=White YW=Yellow SV=Silver
 MG=Magenta GY=Gray GR=Green
 BR=Brown PR=Purple LG=Light Green

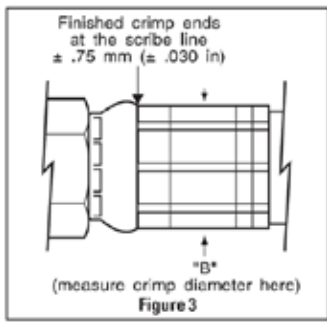

Boston Hose with Z-Series Crimp Style ET4000, T-440

HOSE PART #	HOSE END PREFIX	COLLET PART #	SPACER RING COLOR	SPACER RING PART #	FLAT SIDE UP/DOWN	CATALOG FIGURE	CRIMP DIA. "B"
							±.15 mm ±.006 in
H600208	08 'Z'	ET4000DC-M230S	BK/TN	T-440-78R	UP	3	24.38 mm .960 in
H600212	12 'Z'	T-440-86C	BK/OR	T-440-81R	UP	3	32.92 mm 1.296 in
H600216	16 'Z'	ET4000DC-M380S	N/A	N/A	N/A	3	41.40 mm 1.630 in
H600816	16 'Z'	ET4000DC-M380S	N/A	N/A	N/A	3	41.40 mm 1.630 in
H600820	20 'Z'	ET4000DC-M480S	N/A	N/A	N/A	3	49.78 mm 1.960 in
H600920	20 'Z'	ET4000DC-M480S	N/A	N/A	N/A	3	49.78 mm 1.960 in
H962212	12 'Z'	T-440-86C	BR	ET4000SR-M405A	UP	3	31.75 mm 1.250 in
H962216	16 'Z'	ET4000DC-M380S	N/A	N/A	N/A	3	41.40 mm 1.630 in
H962220	20 'Z'	ET4000DC-M480S	BK/BU	T-440-82R	UP	3	48.26 mm 1.900 in
H994904	04 'Z'	ET4000DC-M150S	YW	T-410-41	UP	3	16.74 mm .659 in
H994906	06 'Z'	ET4000DC-M195S	PR	ET4000SR-M100A	UP	3	20.07 mm .790 in
H994908	08 'Z'	ET4000DC-M230S	BK/TN	T-440-78R	UP	3	24.38 mm .960 in
H994912	12 'Z'	T-440-86C	BK/OR	T-440-81R	UP	3	32.92 mm 1.296 in
H994916	16 'Z'	ET4000DC-M380S	N/A	N/A	N/A	3	41.40 mm 1.630 in

*T-410-25 adapter ring required when using ET400 Series Collets.

BK=Black BU=Blue OR=Orange RD=Red
 TN=Tan WH=White YW=Yellow SV=Silver
 MG=Magenta GY=Gray GR=Green
 BR=Brown PR=Purple LG=Light Green

Eaton
 Hydraulics Operations USA
 14615 Lone Oak Road
 Eden Prairie, MN 55344
 USA
 Tel: 952-937-9800
 Fax: 952-294-7722
 www.hydraulics.eaton.com

Eaton
 Hydraulics Operations Europe
 Route de la Longeraie 7
 1110 Morges
 Switzerland
 Tel: +41 (0) 21 811 4600
 Fax: +41 (0) 21 811 4601

Eaton
 Hydraulic Operations Asia Pacific
 11th Floor Hong Kong New World Tower
 300 Huaihai Zhong Road
 Shanghai 200021
 China
 Tel: 86-21-6387-9988
 Fax: 86-21-6335-3912